

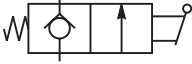

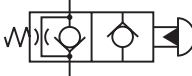
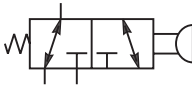

Contents

Manual Valves

	SERIES	CAVITY	DESCRIPTION	FLOW LPM/GPM	PRESSURE BAR/PSI	PAGE NO.
	DL081	C08-2	2 Position, 2 Way, N.C. Poppet, Pull to Open	30/8	210/3000	MV1
	DL101	C10-2	2 Position, 2 Way, N.C. Poppet, Pull to Open	49/13	210/3000	MV2
	GM0212	C08-2	2 Position, 2 Way, N.O. Poppet, Push to Close	45/12	350/5000	MV3
	GM0233	C08-3	2 Position, 3 Way, Spool Type, Pull to Shift	19/5	350/5000	MV4
	DM103	C10-3	3 Way, Rotary Spool	22/6	240/3500	MV5-MV6
	DM104	C10-4	4 Way, Rotary Spool	7/2	240/3500	MV7-MV8
						
	GM0240XS	C08-4	2 Position, 4 Way, Push to Shift	15/4	350/5000	MV9
	GM0240CS	C08-4	2 Position, 4 Way, Push to Shift	15/4	350/5000	MV10
	DMH085C1	C08-4	3 Position, 4 Way, Closed Center, Pull to Shift and Push to Shift	17/5	350/5000	MV11-MV12
	DMH085C4	C08-4	3 Position, 4 Way, Float Center, Pull to Shift and Push to Shift	17/5	350/5000	MV11-MV12
	DMH085C9	C08-4	3 Position, 4 Way, Tandem Center, Pull to Shift and Push to Shift	15/4	350/5000	MV11-MV12
	DMH085C2	C08-4	3 Position, 4 Way, Open Center, Pull to Shift and Push to Shift	15/4	350/5000	MV11-MV12

*DMH085** Series will be available January 1, 2011.*

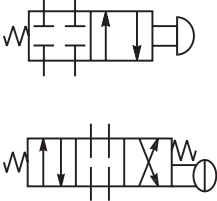
- CV**
Check Valves
- SH**
Shuttle Valves
- LM**
Load/Motor Controls
- FC**
Flow Controls
- PC**
Pressure Controls
- LE**
Logic Elements
- DC**
Directional Controls
- MV**
Manual Valves
- SV**
Solenoid Valves
- PV**
Proportional Valves
- CE**
Coils & Electronics
- BC**
Bodies & Cavities
- TD**
Technical Data

Technical Information

- CV** Check Valves
- SH** Shuttle Valves
- LM** Load/Motor Controls
- FC** Flow Controls
- PC** Pressure Controls
- LE** Logic Elements
- DC** Directional Controls
- MV** Manual Valves
- SV** Solenoid Valves
- PV** Proportional Valves
- CE** Coils & Electronics
- BC** Bodies & Cavities
- TD** Technical Data

General Description

2-Way Manual Poppet Valve. The DL081 Series Valves are suited for emergency lowering applications and on-off flow applications.

Operation

The DL081 Series Valves are mechanically operated check valves. Hydraulic force on the poppet is balanced by having equal area between the poppet seat and the valve stem, allowing the poppet to be manually pulled off the seat. When released, the bias spring will return the valve poppet to its closed position. Back pressure of more than 5.5 Bar (80 PSI) will prevent the bias spring from closing the poppet and must be avoided.

Features

- Low leakage design
- Flip lever, pull handle, or detented pin design
- All external parts zinc plated

Performance Curve

Flow vs. Pressure Drop (Through cartridge only)

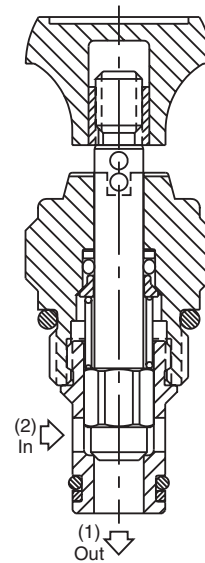
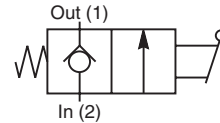
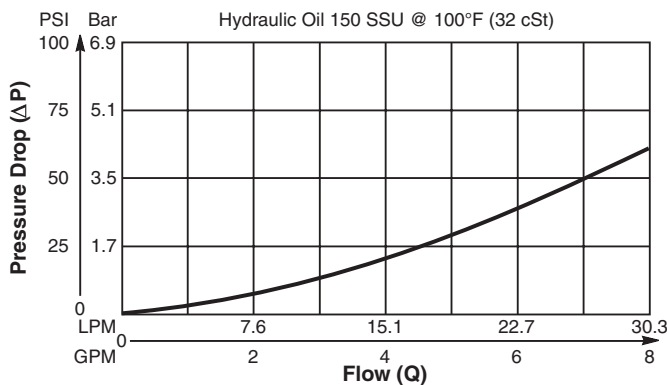

Dimensions Millimeters (Inches)

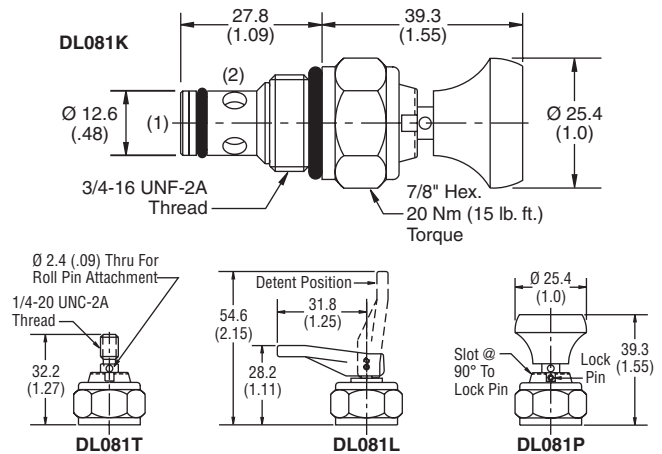

Specifications

Nominal Flow	30 LPM (8 GPM)
Max. Inlet Pressure	210 Bar (3000 PSI)
Leakage at 150 SSU (32 cSt)	5 drops/min. (.33 cc/min.) at 210 Bar (3000 PSI)
Max. Allowable Tankline Pressure	5.5 Bar (80 PSI)
Operating Temp. Range (Ambient)	-40°C to +93.3°C (Nitrile) (-40°F to +200°F) -31.7°C to +121.1°C (Fluorocarbon) (-25°F to +250°F)
Cartridge Material	Stem, stainless steel. All other parts hardened steel.
Filtration	ISO code 16/13, SAE Class 4 or better
Approx. Weight	0.08 kg (0.17 lbs.)
Cavity	C08-2
Form Tool	Rougher None Finisher NFT08-2F

Ordering Information

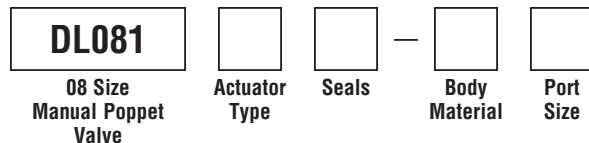

Code	Actuator Type
K	Knob (852525)
T	Stem
L	Lever
P	Lock Pin

Code	Body Material
Omit	Steel
A	Aluminum

Code	Seals / Kit No.
Omit	Nitrile / (SK08-2N)
V	Fluorocarbon / (SK08-2V)

Code	Port Size	Body Part No.
Omit		Cartridge Only
4P	1/4" NPTF	(B08-2-*4P)
6P	3/8" NPTF	(B08-2-*6P)
4T	SAE-4	(B08-2-*4T)
6T	SAE-6	(B08-2-*6T)
6B	3/8" BSPG	(B08-2-*6B)

* Add "A" for aluminum, omit for steel.



General Description

2-Way Manual Poppet Valve. The DL101 Series Valves are suited for emergency lowering applications and on-off flow applications.

Operation

The DL101 Series Valves are mechanically operated check valves. Hydraulic force on the poppet is balanced by having equal area between the poppet seat and the valve stem, allowing the poppet to be manually pulled off the seat. When released, the bias spring will return the valve poppet to its closed position. Back pressure of more than 17.3 Bar (250 PSI) will prevent the bias spring from closing the poppet and must be avoided.

Features

- Low shut-off leakage
- Cartridge design
- Pull-to-Open design
- All external parts zinc plated

Performance Curve

Pressure Drop vs. Flow (Through cartridge only)

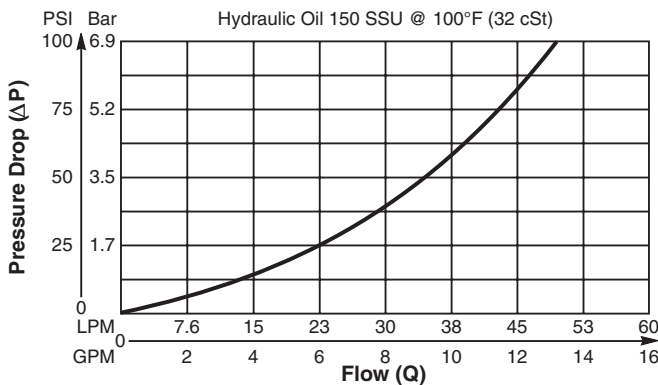

Specifications

Nominal Flow	48.8 LPM (13 GPM)
Max. Inlet Pressure	240 Bar (3500 PSI)
Leakage at 150 SSU (32 cSt)	5 drops/min. (.33 cc/min.) at 240 Bar (3500 PSI)
Max. Allowable Tankline Pressure	17.3 Bar (250 PSI)
Operating Temp. Range (Ambient)	-40°C to +93.3°C (Nitrile) (-40°F to +200°F) -31.7°C to +121.1°C (Fluorocarbon) (-25°F to +250°F)
Cartridge Material	Stem, stainless steel. All other parts hardened steel.
Filtration	ISO code 16/13, SAE Class 4 or better
Approx. Weight	0.09 kg (0.21 lbs.)
Cavity	C10-2
Form Tool	Rougher None Finisher NFT10-2F

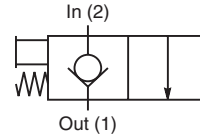
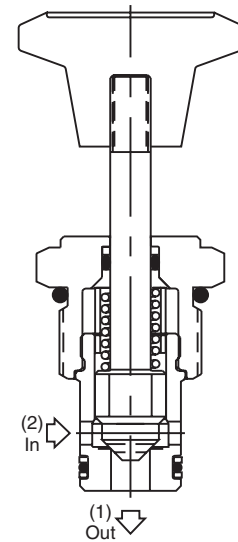

Dimensions Millimeters (Inches)

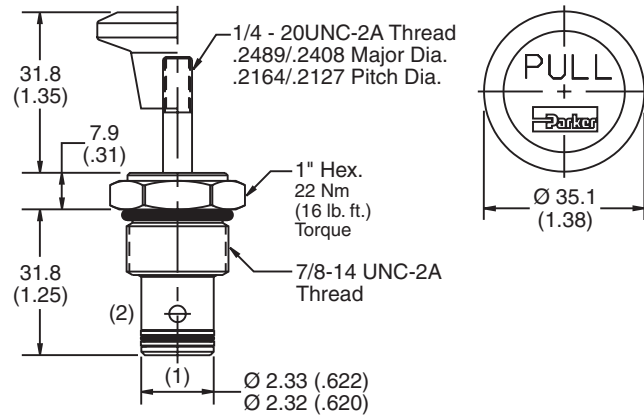

Ordering Information

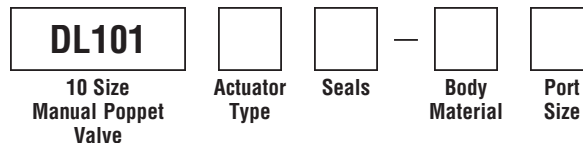

Code	Actuator Type
K	Knob (850020K)
T	Stem

Code	Body Material
Omit	Steel
A	Aluminum

Code	Seals / Kit No.
Omit	Nitrile / (SK10-2N)
V	Fluorocarbon / (SK10-2V)

Code	Port Size	Body Part No.
Omit	Cartridge Only	
4P	1/4" NPTF	(B10-2-*4P)
6P	3/8" NPTF	(B10-2-*6P)
8P	1/2" NPTF	(B10-2-*8P)
6T	SAE-6	(B10-2-*6T)
8T	SAE-8	(B10-2-*8T)
T8T	SAE-8	(B10-2-T8T)†

* Add "A" for aluminum, omit for steel.
† Steel body only.

- CV** Check Valves
- SH** Shuttle Valves
- LM** Load/Motor Controls
- FC** Flow Controls
- PC** Pressure Controls
- LE** Logic Elements
- DC** Directional Controls
- MV** Manual Valves
- SV** Solenoid Valves
- PV** Proportional Valves
- CE** Coils & Electronics
- BC** Bodies & Cavities
- TD** Technical Data

Technical Information

- CV** Check Valves
- SH** Shuttle Valves
- LM** Load/Motor Controls
- FC** Flow Controls
- PC** Pressure Controls
- LE** Logic Elements
- DC** Directional Controls
- MV** Manual Valves
- SV** Solenoid Valves
- PV** Proportional Valves
- CE** Coils & Electronics
- BC** Bodies & Cavities
- TD** Technical Data

General Description

2-Way, 2 Position, Normally Open Manual Poppet Valve.

Features

- Hardened poppet for minimal wear and greater durability
- Poppet type construction for minimal internal leakage
- Internal pilot operation provides “power leverage”
- Cavity common with solenoid operated valves
- Screw-on detent is optional
- All external parts zinc plated

Operation

In neutral position, pressure applied to port 2 creates pilot flow across the pilot seat causing poppet to lift. Flow passes from port 2 to port 1 until manual operator is pushed forcing pilot into its seat preventing pilot flow to firmly close the poppet. In neutral position, flow is restricted from port 1 to port 2.

Performance Curve

Pressure Drop vs. Flow (Through cartridge only)

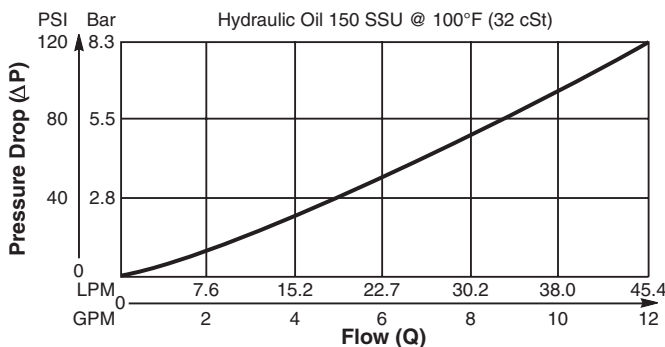

Specifications

Rated Flow	45 LPM (12 GPM)
Maximum Input Pressure @ Port 2	350 Bar (5000 PSI)
Leakage at 150 SSU (32 cSt)	0.33 ml/min. (5 drops/min.) @ 210 Bar (3000 PSI)
Cartridge Material	All parts steel. All operating parts hardened steel.
Operating Temp. Range/Seals	-40°C to +93.3°C (Nitrile, Buna-N) (-40°F to +200°F) -31.7°C to +121.1°C (Fluorocarbon) (-25°F to +250°F)
Fluid Compatibility/Viscosity	Mineral-based or synthetic with lubricating properties at viscosities of 45 to 2000 SSU (6 to 420 cSt)
Filtration	ISO code 16/13, SAE Class 4 or better
Approx. Weight	.13 kg (.31 lbs.)
Cavity	C08-2 (See BC Section for more details)

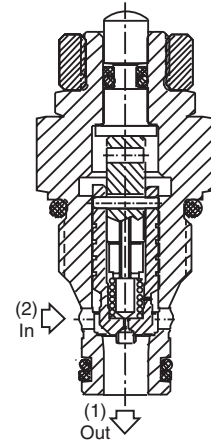
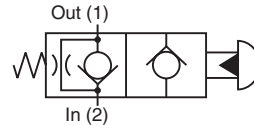

Dimensions Millimeters (Inches)

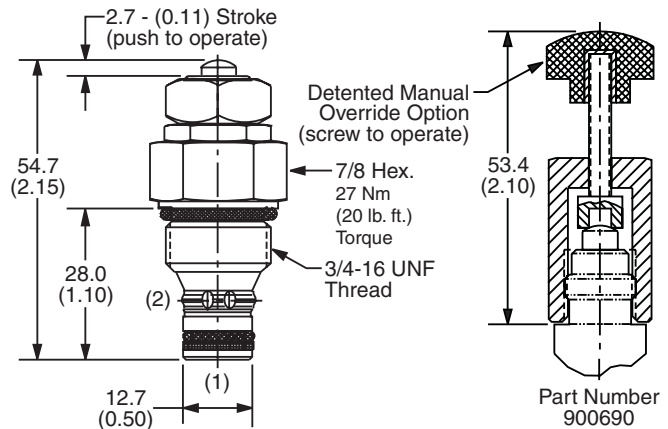

Ordering Information

GM02 12	Manual Button	Filter Screen	Seals	Body Material	Port Size
08 Size Manual Valve Poppet Type Normally Open					

Code	Manual Button
0	Non-Detented (Std.)
1	Detented (With use of part #900690)

Code	Body Material
Omit	Steel
A	Aluminum

Code	Filter Screen
0	Not required
1	60 mesh screen

Code	Port Size	Body Part No.
Omit	Cartridge Only	
4P	1/4" NPTF	(B08-2-*4P)
6P	3/8" NPTF	(B08-2-*6P)
4T	SAE-4	(B08-2-*4T)
6T	SAE-6	(B08-2-*6T)
6B	3/8" BSPG	(B08-2-*6B)

Code	Seals / Kit No.
N	Nitrile, Buna-N / (SK30065N-1)
V	Fluorocarbon / (SK30065V-1)

* Add "A" for aluminum, omit for steel.



Technical Information

General Description

3-Way, 2 Position Manual Spool Valve. Designed to operate single acting cylinders, pilot circuits and uni-directional motors.

Features

- High flow capacity with reduced space requirements
- One piece cartridge housing ensures internal concentricity
- Low mechanical operating force required
- Detented option available
- All external parts zinc plated

Operation

Neutral flow is 2 to 1. Pull to shift for flow from 3 to 2.

Performance Curve

Pressure Drop vs. Flow (Through cartridge only)

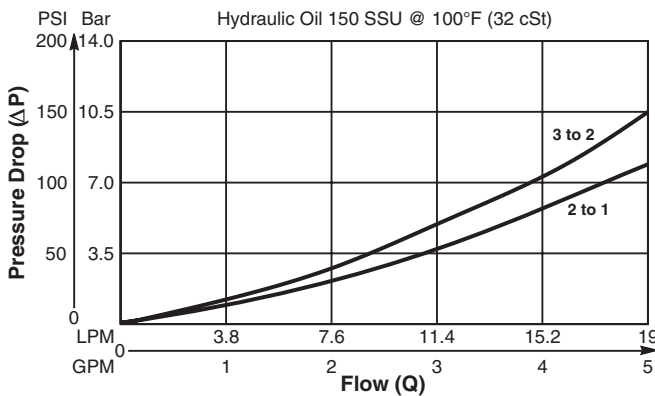

Specifications

Rated Flow	19 LPM (5 GPM)
Operating Pressure	Side Ports - 350 Bar (5000 PSI) Bottom Port - 35 Bar (500 PSI)
Max. Operating Pushing or Pulling Force Required	5 kg (11 lbs.)
Cartridge Material	All parts steel. All operating parts hardened steel.
Operating Temp. Range/Seals	-40°C to +93.3°C (Nitrile, Buna-N) (-40°F to +200°F) -31.7°C to +121.1°C (Fluorocarbon) (-25°F to +250°F)
Fluid Compatibility/Viscosity	Mineral-based or synthetic with lubricating properties at viscosities of 45 to 2000 SSU (6 to 420 cSt)
Filtration	ISO code 16/13, SAE Class 4 or better
Approx. Weight	.10 kg (.20 lbs.)
Cavity	C08-3 (See BC Section for more details)

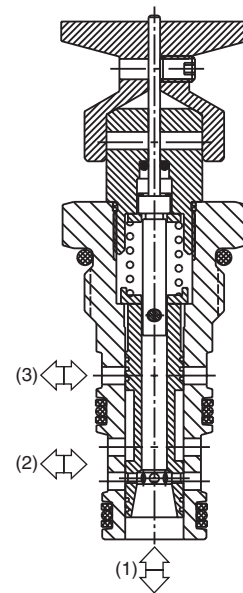
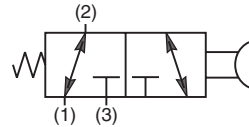
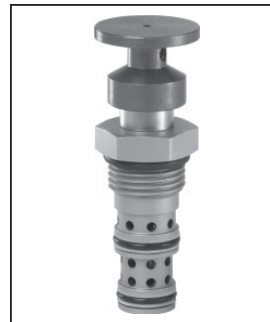

Dimensions Millimeters (Inches)

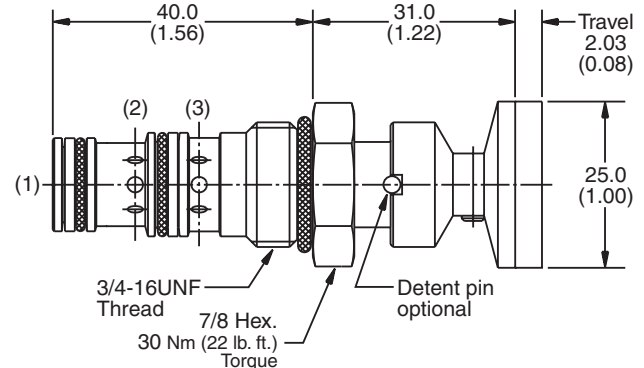

Ordering Information

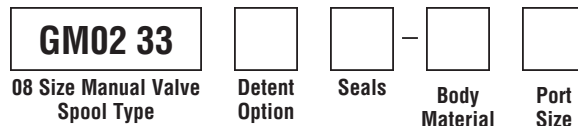

Code	Detent Option
Omit	Non-Detented (Std.)
1	Detented

Code	Body Material
Omit	Steel
A	Aluminum

Code	Seals / Kit No.
N	Nitrile, Buna-N / (SK30077N-1)
V	Fluorocarbon / (SK30077V-1)

Code	Port Size	Body Part No.
Omit	Cartridge Only	
4P	1/4" NPTF	(B08-3-*4P)
4T	SAE-4	(B08-3-*4T)
6T	SAE-6	(B08-3-*6T)
6B	3/8" BSPG	(B08-3-*6B)

* Add "A" for aluminum, omit for steel.

- CV** Check Valves
- SH** Shuttle Valves
- LM** Load/Motor Controls
- FC** Flow Controls
- PC** Pressure Controls
- LE** Logic Elements
- DC** Directional Controls
- MV** Manual Valves
- SV** Solenoid Valves
- PV** Proportional Valves
- CE** Coils & Electronics
- BC** Bodies & Cavities
- TD** Technical Data

Technical Information

- CV** Check Valves
- SH** Shuttle Valves
- LM** Load/Motor Controls
- FC** Flow Controls
- PC** Pressure Controls
- LE** Logic Elements
- DC** Directional Controls
- MV** Manual Valves
- SV** Solenoid Valves
- PV** Proportional Valves
- CE** Coils & Electronics
- BC** Bodies & Cavities
- TD** Technical Data

General Description

3-Way Rotary Spool Valve. The DM103 Series Valves are suited for any 3-way application (such as a selector function) where manual operation is desired. For additional information see Technical Tips pages MV1-MV2.

Features

- Several lever and knob options available
- Detented versions available
- Serviceable cartridge design
- All external parts zinc plated

Operation

The K, LD, and FKD options require a full 90° rotation to shift the spool from one offset position to the other. The LN and FKN options require a full 45° rotation from center to either offset position. The knob (or lever) position indicator can be positioned anywhere within the 360° circle.

Specifications

Nominal Flow	22.5 LPM (6 GPM)
Maximum Inlet Pressure	240 Bar (3500 PSI)
Degrees of Rotation	K, LD, and FKD Styles: 90° from Offset to Offset (2 positions) LN, FKN Style: 45° from center to either Offset (3 positions)
Leakage at 150 SSU (32 cSt)	164 cc/min. at 240 Bar (3500 PSI)
Cartridge Material	Stem, stainless steel. All other parts hardened steel.
Operating Temp. Range/Seals	-40°C to +93.3°C (Nitrile) (-40°F to +200°F) -31.7°C to +121.1°C (Fluorocarbon) (-25°F to +250°F)
Fluid Compatibility/Viscosity	Mineral-based or synthetic with lubricating properties at viscosities of 45 to 2000 SSU (6 to 420 cSt)
Filtration	ISO code 16/13, SAE Class 4 or better
Approx. Weight	0.11 kg (.30 lbs.)
Cavity	C10-3 (See BC Section for more details)
Form Tool	Rougher NFT10-3R Finisher NFT10-3F

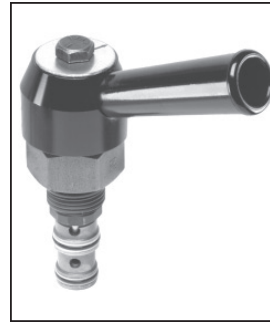

DM103LD

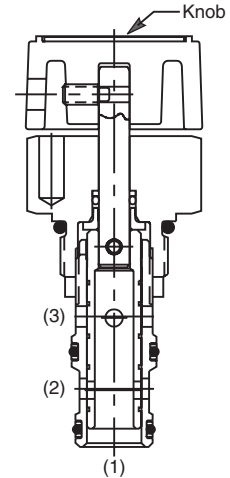
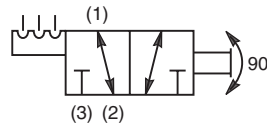

Performance Curve
Flow vs. Pressure Drop
(Through cartridge only)

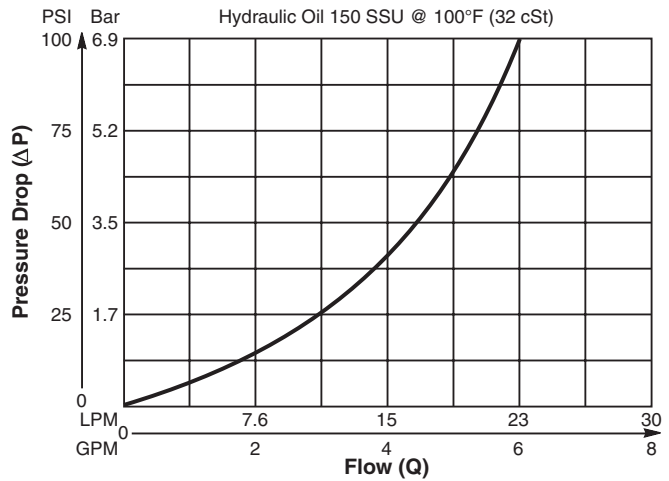

Dimensions Millimeters (Inches)

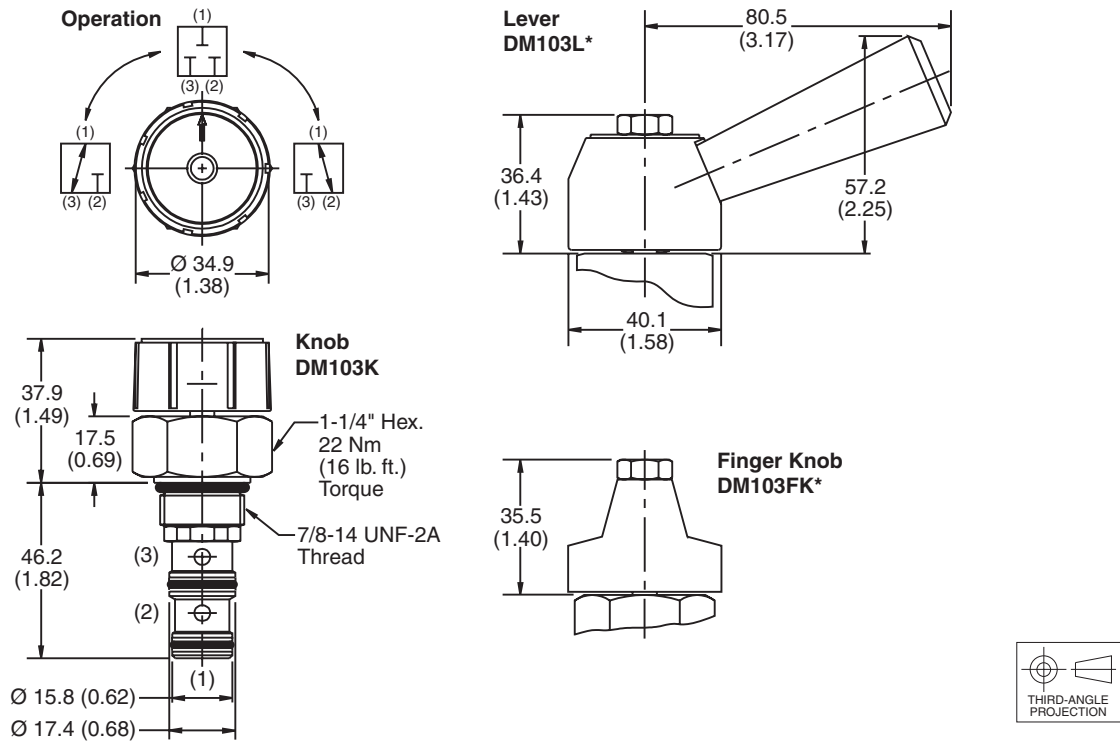

Ordering Information

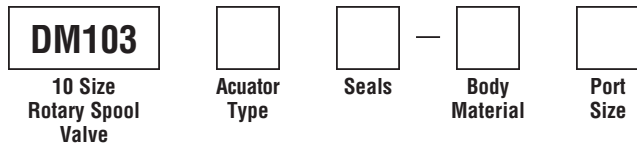

Code / Actuator Type	
K Knob	
LD Lever with 2 position detent	
LN Lever with 3 position detent	
FKD Finger Knob with 2 position detent	
FKN Finger Knob with 3 position detent	

Code	Seals / Kit. No.
Omit	Nitrile / (SK10-3N)
V	Fluorocarbon / (SK10-3V)

Code	Body Material
Omit	Steel
A	Aluminum

Code	Port Size	Body Part No.
Omit	Cartridge Only	
4P	1/4" NPTF	(B10-3-*4P)
6P	3/8" NPTF	(B10-3-*6P)
8P	1/2" NPTF	(B10-3-*8P)
4T	SAE - 4	(B10-3-*4T)
6T	SAE - 6	(B10-3-*6T)
6B	3/8" BSPG	(B10-3-6B)†
8B	1/2" BSPG	(B10-3-*8B)

* Add "A" for aluminum, omit for steel.
 † Steel body only.

- CV** Check Valves
- SH** Shuttle Valves
- LM** Load/Motor Controls
- FC** Flow Controls
- PC** Pressure Controls
- LE** Logic Elements
- DC** Directional Controls
- MV** Manual Valves
- SV** Solenoid Valves
- PV** Proportional Valves
- CE** Coils & Electronics
- BC** Bodies & Cavities
- TD** Technical Data

Technical Information

- CV** Check Valves
- SH** Shuttle Valves
- LM** Load/Motor Controls
- FC** Flow Controls
- PC** Pressure Controls
- LE** Logic Elements
- DC** Directional Controls
- MV** Manual Valves
- SV** Solenoid Valves
- PV** Proportional Valves
- CE** Coils & Electronics
- BC** Bodies & Cavities
- TD** Technical Data

General Description

4-Way Rotary Spool Valve. The DM104 Series Valves are suited for all 4-way directional control applications where manual operation is desired.

Features

- Several lever and knob options available
- Detented versions available
- Serviceable cartridge design
- All external parts zinc plated

Operation

The K, LD, and FKD options require a full 90° rotation to shift the spool from one offset position to the other. The LN and FKN options require a full 45° rotation from center to either offset position. The knob (or lever) position indicator can be positioned anywhere within the 360° circle.

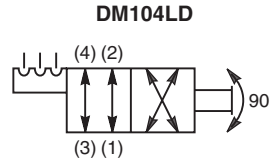
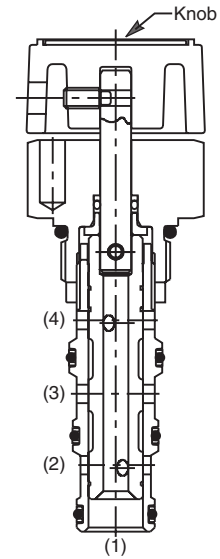
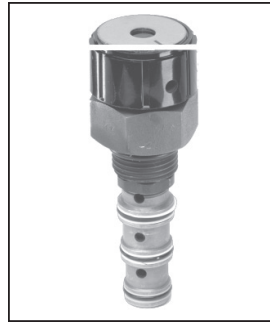

Specifications

Nominal Flow	7.5 LPM (2 GPM)
Maximum Inlet Pressure	240 Bar (3500 PSI)
Degrees of Rotation	K, LD, and FKD Styles: 90° from Offset to Offset (2 positions) LN and FKN Styles: 45° from center to either Offset (3 positions)
Leakage at 150 SSU (32 cSt)	164 cc/min. at 240 Bar (3500 PSI)
Cartridge Material	All parts steel. All operating parts hardened steel.
Operating Temp. Range/Seals	-40°C to +93.3°C (Nitrile) (-40°F to +200°F) -31.7°C to +121.1°C (Fluorocarbon) (-25°F to +250°F)
Fluid Compatibility/Viscosity	Mineral-based or synthetic with lubricating properties at viscosities of 45 to 2000 SSU (6 to 420 cSt)
Filtration	ISO code 16/13, SAE Class 4 or better
Approx. Weight	0.11 kg (.30 lbs.)
Cavity	C10-4 (See BC Section for more details)
Form Tool	Rougher NFT10-4R Finisher NFT10-4F

Performance Curve

Flow vs. Pressure Drop
(Through cartridge only)

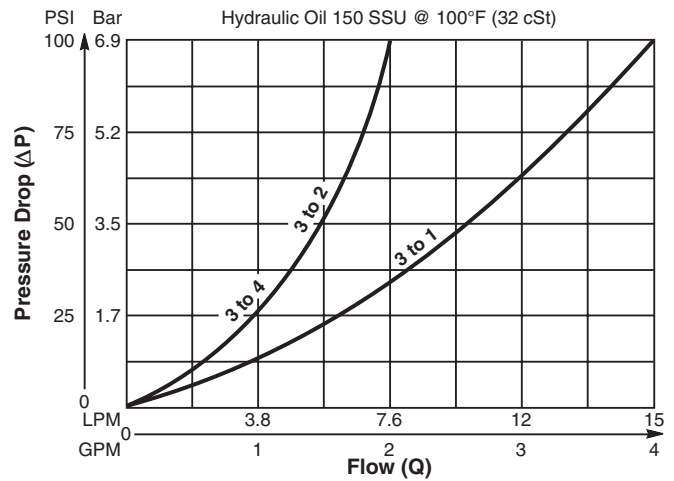

Dimensions Millimeters (Inches)

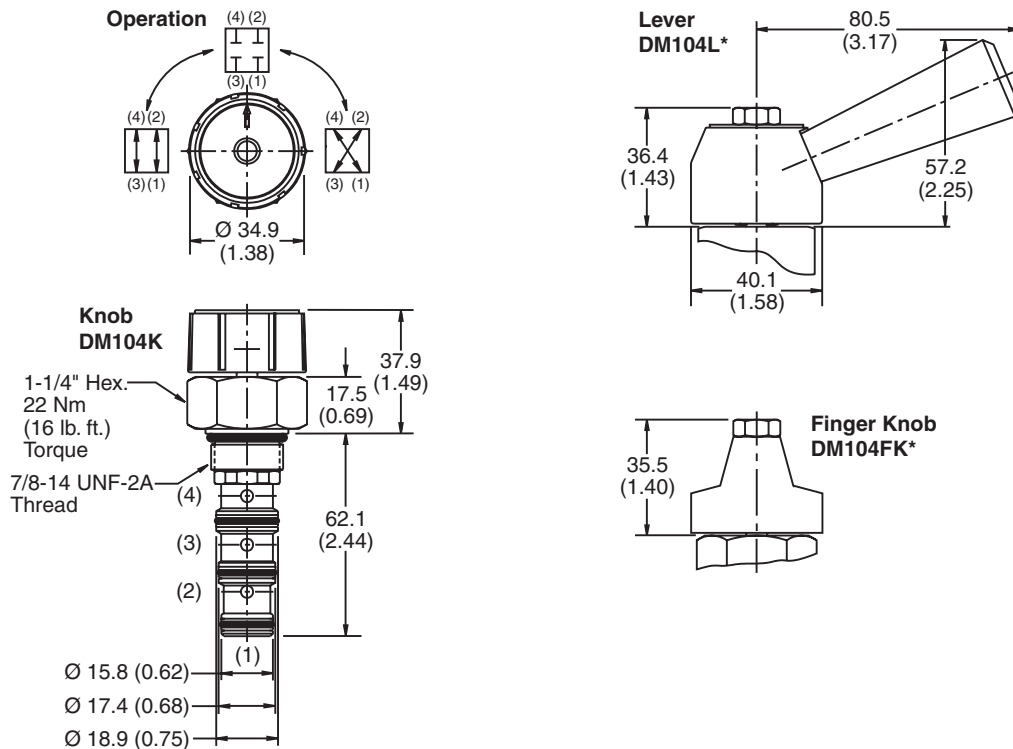

Ordering Information

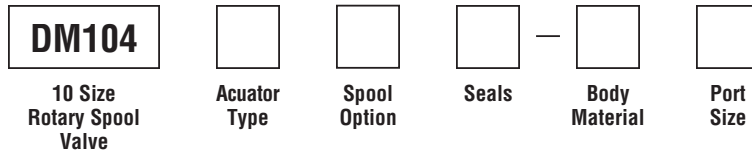

Code / Actuator Type	Diagram
K Knob	
LD Lever with 2 position detent	
LN Lever with 3 position detent	
FKD Finger Knob with 2 position detent	
FKN Finger Knob with 3 position detent	

Code / Spool Option	Diagram
1 Closed Center	
8 Tandem Center	

Code	Seals / Kit. No.
Omit	Nitrile / (SK10-4N)
V	Fluorocarbon / (SK10-4V)

Code	Body Material
Omit	Steel
A	Aluminum

Code	Port Size	Body Part No.
Omit	Cartridge Only	
6P	3/8" NPTF	(B10-4-*6P)
6T	SAE - 6	(B10-4-*6T)
8T	SAE - 8	(B10-4-*8T)
6B	3/8" BSPG	(B10-4-6B)†

* Add "A" for aluminum, omit for steel.
 † Steel body only.

- CV**
Check Valves
- SH**
Shuttle Valves
- LM**
Load/Motor Controls
- FC**
Flow Controls
- PC**
Pressure Controls
- LE**
Logic Elements
- DC**
Directional Controls
- MV**
Manual Valves
- SV**
Solenoid Valves
- PV**
Proportional Valves
- CE**
Coils & Electronics
- BC**
Bodies & Cavities
- TD**
Technical Data

Technical Information

- CV Check Valves
- SH Shuttle Valves
- LM Load/Motor Controls
- FC Flow Controls
- PC Pressure Controls
- LE Logic Elements
- DC Directional Controls
- MV Manual Valves
- SV Solenoid Valves
- PV Proportional Valves
- CE Coils & Electronics
- BC Bodies & Cavities
- TD Technical Data

General Description

4-Way, 2 Position, Reversing Manual Spool Valve. Designed to operate double acting cylinders, pilot circuits and bi-directional motors.

Features

- High flow capacity with reduced space requirements
- One piece cartridge housing ensures internal concentricity
- Low mechanical operating force required
- Detented option available
- All external parts zinc plated

Operation

Neutral, flow is 3 to 4 and 2 to 1. Push to shift for flow 3 to 2 and 4 to 1

Performance Curve

Pressure Drop vs. Flow (Through cartridge only)

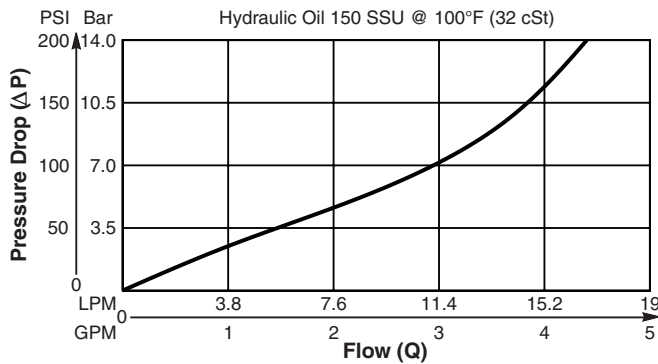

Specifications

Rated Flow	15 LPM (4 GPM)
Operating Pressure	Side Ports - 350 Bar (5000 PSI) Bottom Port - 35 Bar (500 PSI)
Max. Operating Pushing or Pulling Force Required	5 kg (11 lbs.)
Cartridge Material	All parts steel. All operating parts hardened steel.
Operating Temp. Range/Seals	-40°C to +93.3°C (Nitrile, Buna-N) (-40°F to +200°F) -31.7°C to +121.1°C (Fluorocarbon) (-25°F to +250°F)
Fluid Compatibility/Viscosity	Mineral-based or synthetic with lubricating properties at viscosities of 45 to 2000 SSU (6 to 420 cSt)
Filtration	ISO code 16/13, SAE Class 4 or better
Approx. Weight	.10 kg (.20 lbs.)
Cavity	C08-4 (See BC Section for more details)

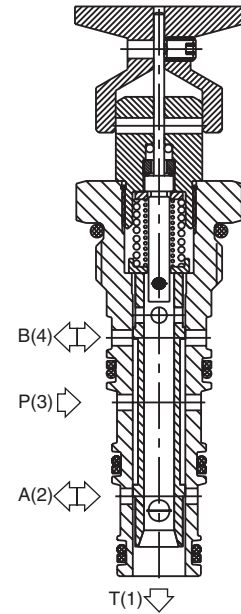
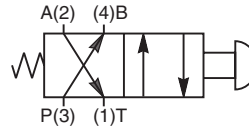

Dimensions Millimeters (Inches)

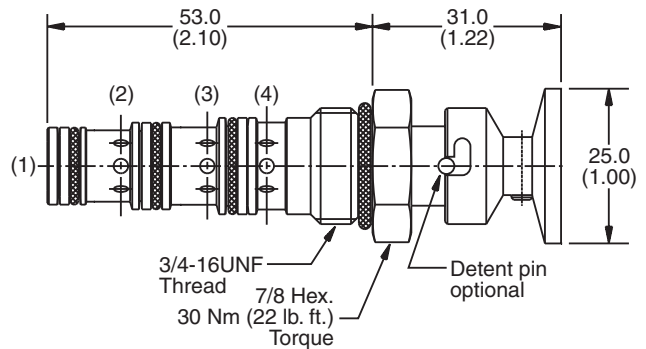

Ordering Information

GM02 40XS -

08 Size Manual Valve Detent Option Seals Body Material Port Size
Spool Type Reversing

Code	Detent Option
Omit	Non-Detented (Std.)
1	Detented

Code	Body Material
Omit	Steel
A	Aluminum

Code	Seals / Kit No.
N	Nitrile, Buna-N / (SK30078N-1)
V	Fluorocarbon / (SK30078V-1)

Code	Port Size	Body Part No.
Omit	Cartridge Only	
4T	SAE-4	(B08-4-*4T)
6T	SAE-6	(B08-4-*6T)
6B	3/8" BSPG	(B08-4-*6B)

* Add "A" for aluminum, omit for steel.

Technical Information

General Description

4-Way, 2 Position, Normally Closed Manual Spool Valve. Designed to operate double acting cylinders, pilot circuits and bi-directional motors.

Features

- High flow capacity with reduced space requirements
- One piece cartridge housing ensures internal concentricity
- Low mechanical operating force required
- Detented option available
- All external parts zinc plated

Operation

Neutral, all ports blocked. Push to shift for flow 3 to 2 and 4 to 1.

Performance Curve

Pressure Drop vs. Flow (Through cartridge only)

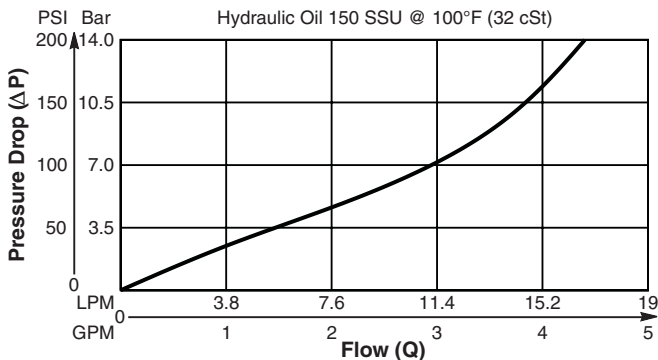

Specifications

Rated Flow	15 LPM (4 GPM)
Operating Pressure	Side Ports - 350 Bar (5000 PSI) Bottom Port - 35 Bar (500 PSI)
Max. Operating Pushing or Pulling Force Required	5 kg (11 lbs.)
Cartridge Material	All parts steel. All operating parts hardened steel.
Operating Temp. Range/Seals	-40°C to +93.3°C (Nitrile, Buna-N) (-40°F to +200°F) -31.7°C to +121.1°C (Fluorocarbon) (-25°F to +250°F)
Fluid Compatibility/Viscosity	Mineral-based or synthetic with lubricating properties at viscosities of 45 to 2000 SSU (6 to 420 cSt)
Filtration	ISO code 16/13, SAE Class 4 or better
Approx. Weight	.12 kg (.25 lbs.)
Cavity	C08-4 (See BC Section for more details)

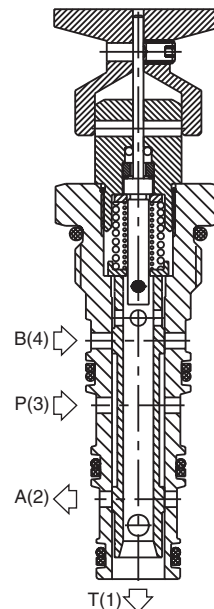
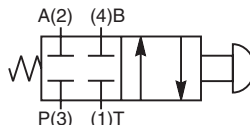

Dimensions Millimeters (Inches)

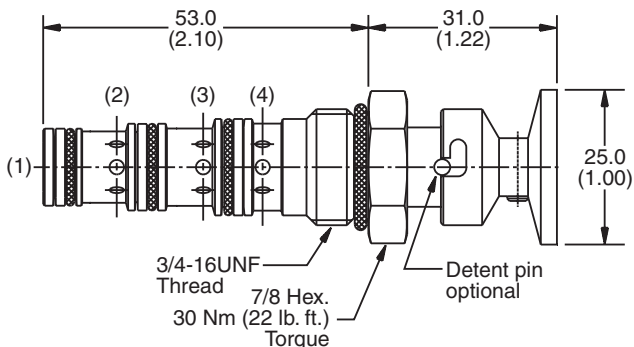

Ordering Information

GM02 40CS

08 Size Manual Valve Detent Option Seals Body Material Port Size
Spool Type Normally Closed

Code	Detent Option
Omit	Non-Detented (Std.)
1	Detented

Code	Body Material
Omit	Steel
A	Aluminum

Code	Seals / Kit No.
N	Nitrile, Buna-N / (SK30078N-1)
V	Fluorocarbon / (SK30078V-1)

Code	Port Size	Body Part No.
Omit	Cartridge Only	
4T	SAE-4	(B08-4-*4T)
6T	SAE-6	(B08-4-*6T)
6B	3/8" BSPG	(B08-4-*6B)

* Add "A" for aluminum, omit for steel.

- CV** Check Valves
- SH** Shuttle Valves
- LM** Load/Motor Controls
- FC** Flow Controls
- PC** Pressure Controls
- LE** Logic Elements
- DC** Directional Controls
- MV** Manual Valves
- SV** Solenoid Valves
- PV** Proportional Valves
- CE** Coils & Electronics
- BC** Bodies & Cavities
- TD** Technical Data

Technical Information

- CV** Check Valves
- SH** Shuttle Valves
- LM** Load/Motor Controls
- FC** Flow Controls
- PC** Pressure Controls
- LE** Logic Elements
- DC** Directional Controls
- MV** Manual Valves
- SV** Solenoid Valves
- PV** Proportional Valves
- CE** Coils & Electronics
- BC** Bodies & Cavities
- TD** Technical Data

General Description

4-Way, 3 Position, Closed Center Manual Spool Valve. Designed to operate double acting cylinders, pilot circuits and bi-directional motors.

Features

- High flow capacity with reduced space requirements
- One piece cartridge housing ensures internal concentricity
- Low mechanical operating force required
- Detented option available
- All external parts zinc plated

Operation

Push to shift for flow 3 to 2 and 4 to 1. Pull to shift for flow 3 to 4 and 2 to 1.

NOTE:

This series will be available January 1, 2011.

Specifications

Rated Flow	C1 17 LPM (4.5 GPM) C2 15 LPM (4.0 GPM) C4 19 LPM (5.0 GPM) C9 15 LPM (4.0 GPM)
Operating Pressure	Side Ports - 350 Bar (5000 PSI) Bottom Port - 35 Bar (500 PSI)
Max. Operating Pushing or Pulling Force Required	5 kg (11 lbs.)
Cartridge Material	All parts steel. All operating parts hardened steel.
Operating Temp. Range/Seals	-45°C to +93.3°C ("D"-Ring) (-50°F to +200°F) -31.7°C to +121.1°C (Fluorocarbon) (-25°F to +250°F)
Fluid Compatibility/Viscosity	Mineral-based or synthetic with lubricating properties at viscosities of 45 to 2000 SSU (6 to 420 cSt)
Filtration	ISO code 16/13, SAE Class 4 or better
Approx. Weight	.12 kg (.25 lbs.)
Cavity	C08-4 (See BC Section for more details)

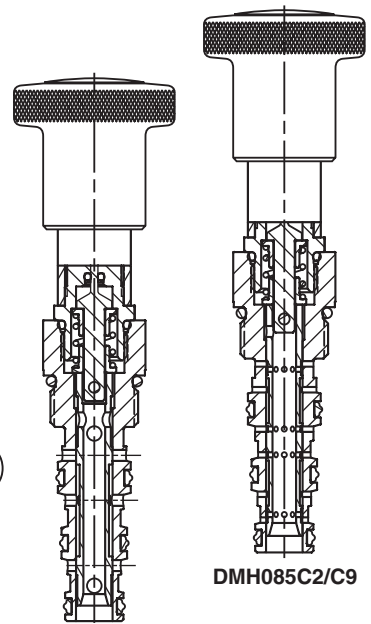
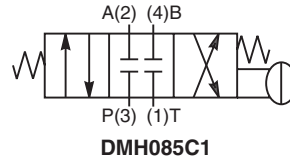

DMH085C1/C4

DMH085C2/C9

Dimensions Millimeters (Inches)

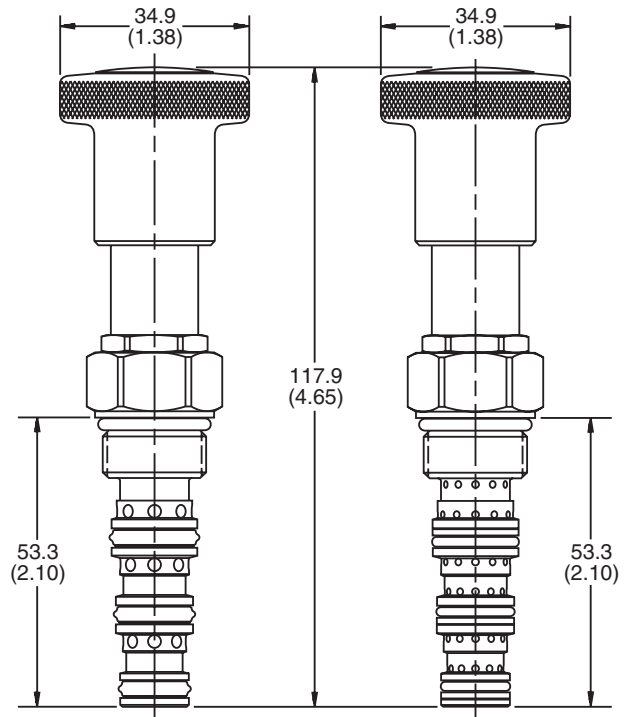

DMH085C1/C4

DMH085C2/C9

Note: "D"-Rings are standard on all spool configurations, but optional Buna/Fluorocarbon configurations as shown on the C2/C9 drawing are also available.

Performance Curves

Pressure Drop vs. Flow (Through cartridge only)

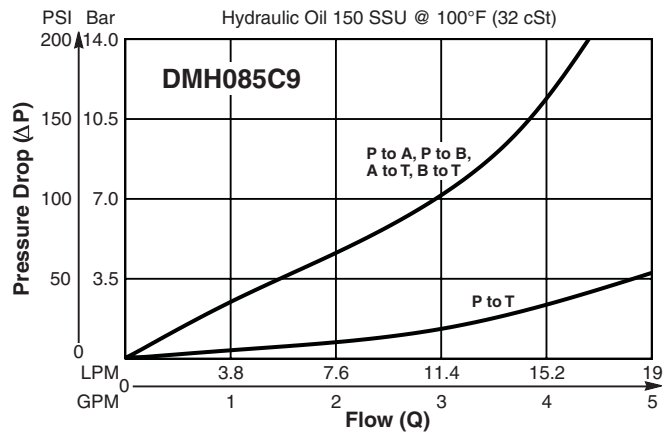
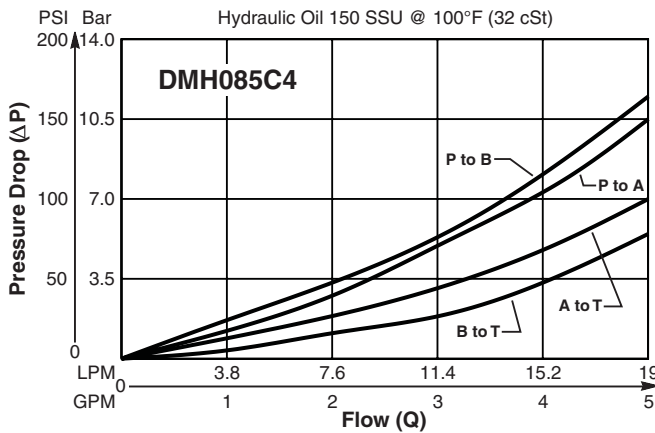
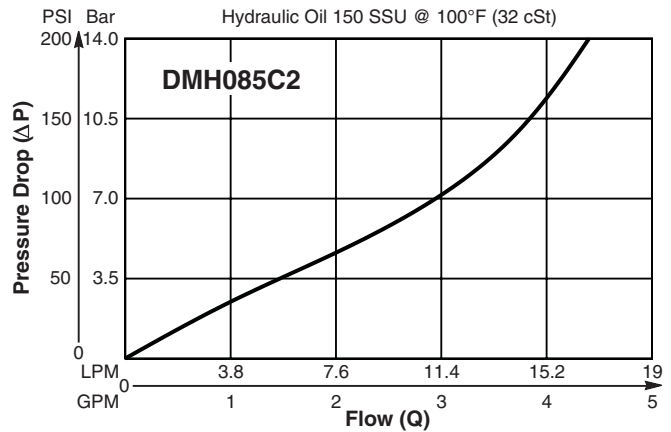
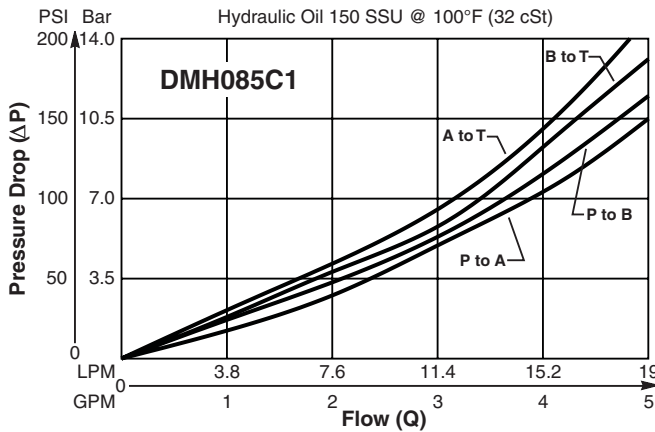

Ordering Information

DMH085

08 Size, 4-Way Spool Type Manual Valve Style Detent Option Seals Body Material Port Size

NOTE:
 This series will be available January 1, 2011.

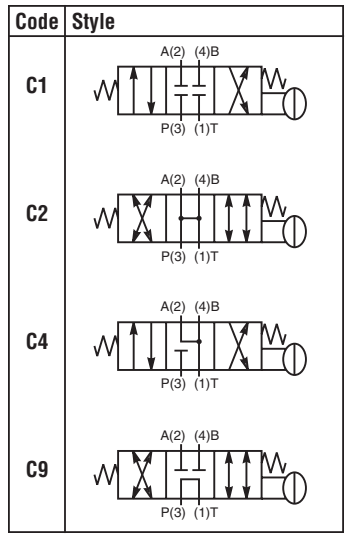

Code	Detent Option
Omit	Non-Detented (Std.)
D	Detented

Code	Body Material
Omit	Steel
A	Aluminum

Code	Seals / Kit No.
Omit	"D"-Ring / (SK08-2)
N	Nitrile / (SK08-2N)
V	Fluorocarbon / (SK08-2V)

Code	Port Size	Body Part No.
Omit	Cartridge Only	
4T	SAE-4	(B08-4-*4T)
6T	SAE-6	(B08-4-*6T)
6B	3/8" BSPG	(B08-4-*6B)

* Add "A" for aluminum, omit for steel.



- CV**
Check Valves
- SH**
Shuttle Valves
- LM**
Load/Motor Controls
- FC**
Flow Controls
- PC**
Pressure Controls
- LE**
Logic Elements
- DC**
Directional Controls
- MV**
Manual Valves
- SV**
Solenoid Valves
- PV**
Proportional Valves
- CE**
Coils & Electronics
- BC**
Bodies & Cavities
- TD**
Technical Data